

OBRATOV. URE
KOMPRESORJA
DISPLAY KAŽE
ŠT. UR DELOV.
DELJENO Z 10
55 = 550 UR
ZA PONIČENJE
PRITISNITE
ISTOČASNO
TIPKI GOR+DOL

VNOS KODE
ZA NASTAVLJ.
OSTALIH
PARAMETROV
JE POTREBNO
VNESTI KODO
>> 011 <<
IN POTRDI S
TIPKO

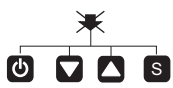
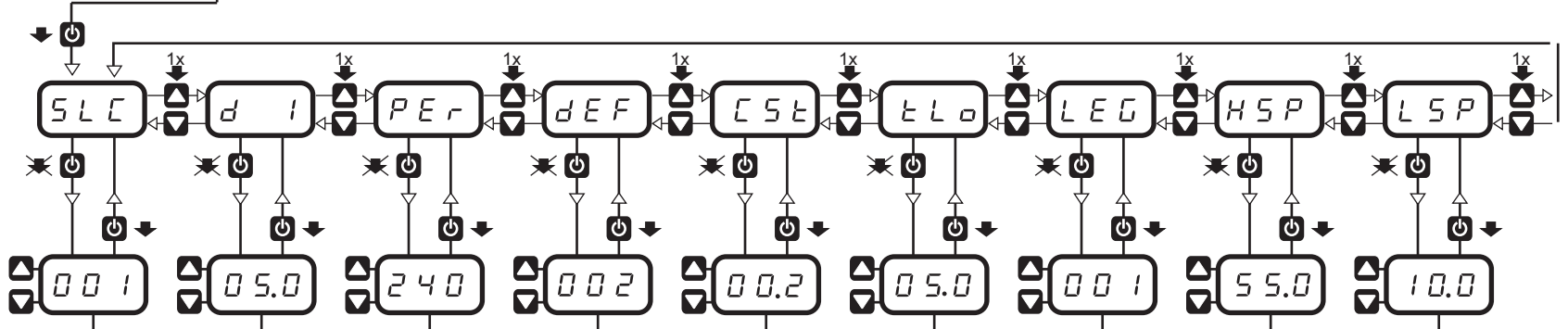

ČE NOBENA
TIPKA NI
PRITISNJENA
ZAČNE DISPLAY
UTRIPATI IN PO
10 SEKUNDAH
JE NASTAVLJ.
KONČANO

<p>NAČIN DELOV.</p> <p>Kletna SLC = 0 Bojler SLC = 1 Boj - Var SLC = 2</p>	<p>DIFERENCA VKLOP-IZKLOP KOMPRESORJA</p> <p>MIN = 0 C MAX = 20 C</p>	<p>ČAS MED DVEMA ODTALJEVANJ.</p> <p>MIN = DEF x 2 MAX = 240 M</p>	<p>ČAS ODTALJEVANJA</p> <p>MIN = 0 M MAX = PdE / 2</p>	<p>MINIMALNI ČAS MIROVANJA KOMPRESORJA</p> <p>MIN = 0 M MAX = 20 M</p>	<p>MINIMALNA TEMPERATURA PROSTORA</p> <p>MIN = -9,9 C MAX = 10,0 C</p>	<p>PROTILEGIONEL PROGRAM</p> <p>0 = NI 1 = PROTILEG</p>	<p>OMEJITEV NASTAVITVE NAJVIŠJE TEMPERATURE</p> <p>MIN = LSP MAX = 99,9 C</p>	<p>OMEJITEV NASTAVITVE NAJNIŽJE TEMPERATURE</p> <p>MIN = 0 C MAX = HSP</p>
--	---	--	--	--	--	---	---	--

Kletna SLC = 0	2,0	240	2,0	2	X	X	55,0	10,0
Bojler SLC = 1	5,0	240	2,0	2	X	1	55,0	10,0
Boj - Var SLC = 2	4,0	240	2,0	2	5,0	1	55,0	10,0

VAŠA NASTAVITEV